

Unplasticized polyvinyl chloride (PVC-U)
drainpipes
Dimensions, requirements, testing

DIN
1187

Dränrohre aus weichmacherfreiem Polyvinylchlorid (PVC hart); Masse, Anforderungen, Prüfungen

Supersedes July 1975 edition

As it is current practice in standards published by the International Organization for Standardization (ISO), the comma has been used throughout as a decimal marker.

Dimensions in mm

Contents

	Page		Page
1 Field of application	2	5.4 Weight	3
2 Dimensions, designation, weight	2	5.5 Falling ball test	3
2.1 Designation	2	5.6 Deformation test	3
2.2 Diameter, wall thickness and socket depth	2	5.7 Tensile test on corrugated pipes with socket joint	4
2.3 Length and form at delivery	2	5.8 Insertion test on smooth pipes with socket joint	4
2.4 Weight	2	5.9 Marking	4
3 Material (moulding material)	2	6 Verification of suitability, internal control and supervision	4
4 Requirements	2	6.1 General	4
4.1 Condition on delivery	2	6.2 Verification of suitability	4
4.2 Pipe joints	3	6.3 Internal control and third party supervision	5
4.3 Water inlet apertures	3	6.4 Test certificate	5
4.4 Behaviour in falling ball test	3	6.5 Repeat test	5
4.5 Behaviour in deformation test	3	7 Marking	5
4.6 Behaviour of corrugated pipes with socket joint in tensile test	3	7.1 Corrugated pipes	5
4.7 Behaviour of smooth pipes in socket insertion test	3	7.2 Smooth pipes	5
5 Testing	3	7.3 Nests and stacks of pipes	5
5.1 Condition on delivery	3	Standards referred to	6
5.2 Dimensions	3	Further standards	6
5.3 Water inlet apertures	3		

Continued on pages 2 to 6

1 Field of application

This standard applies to unplasticized polyvinyl chloride (PVC-U) corrugated (flexible) and smooth (rod) drain-pipes mainly used for the control of the soil water balance in accordance with DIN 1185 Part 1 to Part 5. The pipes are manufactured by extrusion. They are internally and externally circular and have apertures to permit entry of water. In the following only the terms "corrugated pipes" and "smooth pipes" are used.

2 Dimensions, designation, weight

2.1 Designation

Type A corrugated pipe

Designation of a corrugated pipe (A) of nominal size 80 and with narrow water inlet apertures of 0,8 mm in width in accordance with subclause 4.3.2:

Drainpipe DIN 1187 – A 80 – 0,8

Type B smooth pipe

Designation of a smooth pipe (B) of nominal size 90 and with medium-sized water inlet apertures of 1,2 mm in width in accordance with subclause 4.3.2:

Drainpipe DIN 1187 – B 90 – 1,2

2.2 Diameter, wall thickness and socket depth

The diameter, wall thickness and socket depth are specified in tables 1 and 2.

Table 1. Corrugated pipes (type A)

Nominal size *) (DN)	Outside diameter		Inside diameter min.
		per. dev.	
50	50	+ 0,5 - 0,5	44
65	65	+ 0,5 - 0,5	58
80	80	+ 0,5 - 0,5	71,5
100	100	+ 0,5 - 0,5	91
125	125,5	+ 0,5 - 1	115
160	159,5	+ 0,5 - 1	144
200	199,5	+ 0,5 - 1	182

*) The nominal size DN is a parameter without unit and is not the same as the inside diameter of the pipes. Therefore when determining the hydraulic efficiency in accordance with DIN 1185 Part 2, December 1973 edition, table 8 and figure 9, the calculations are based on the inside diameter of the pipes in accordance with this standard (with the exception of DN 160).

Table 2. Smooth pipes (type B)

Nominal size (DN)	Outside diameter		Wall thickness		Inside diameter min.	Socket depth min.
		per. dev.		per. dev.		
50	50	+ 0,3 0	1	+ 0,5 0	47	75
63	63	+ 0,4 0	1,3	+ 0,6 0	59	90
75	75	+ 0,4 0	1,5	+ 0,7 0	71	105
90	90	+ 0,5 0	1,8	+ 0,8 0	85	115
110	110	+ 0,6 0	1,9	+ 0,8 0	105	120
125	125	+ 0,7 0	2	+ 0,8 0	119	125
140	140	+ 0,8 0	2,3	+ 0,9 0	134	125
160	160	+ 0,8 0	2,5	+ 1 0	153	125

2.3 Length and form at delivery

Corrugated pipes shall be supplied in nests, smooth pipes including socket in lengths of 5 m.

2.4 Weight

The minimum weight of corrugated pipes is dependent on the profile. It must be specified by the pipe manufacturer to the test centre, responsible for third party supervision, in kg per 1 m length of pipe. The weight of nests or smooth pipes as transported must be taken from the manufacturer's documents.

3 Material (moulding material)

U-PVC made from unplasticized PVC moulding material conforming to DIN 7748 Part 1. The choice and proportioning of the vinyl chloride homopolymers, stabilizers, lubricants and other additives (e.g. pigments) for the moulding material are left to the manufacturer's discretion.

Moulding materials of uncontrolled composition shall not be used.

4 Requirements

4.1 Condition on delivery

The pipes must have a smooth internal and external surface in accordance with the manufacturing process. They shall be free of nonhomogeneity and have no pores, bubbles, cracks or other defects.

Slight shallow longitudinal marks or irregularities in the wall thickness are permissible if the other properties are not affected by these.

The ends of the pipes must be cut off vertically to the pipe axis. The colouring of the pipes is left to the manufacturer's discretion.

Corrugated pipes must have an even profile. Smooth pipes must be straight.

4.2 Pipe joints

4.2.1 General

The pipes shall be joined by means of sockets.

4.2.2 Corrugated pipes

The design of the socket is left to the manufacturer's discretion. The pipe joint must have sufficient longitudinal connective strength to permit mechanical laying (see subclause 4.6).

4.2.3 Smooth pipes

The sockets shall be moulded onto the pipe. They shall be designed with a slight taper to ensure sufficient longitudinal connective strength (see figure 1).

The minimum socket depth can be taken from table 2.

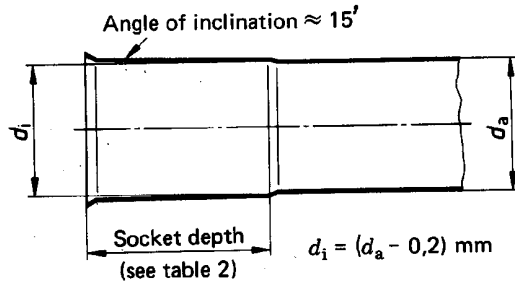

Figure 1. Tapered socket for smooth pipes

4.3 Water inlet apertures

4.3.1 Water inlet area

The minimum water inlet area per metre pipe length must be 8 cm².

The water inlet apertures must be arranged uniformly in at least 5 rows over the circumference of the pipe. They must be constructed in such a way that the entry and flow of water through the pipe is not obstructed by residual material.

4.3.2 Width

The width of the water inlet apertures is equal to the length of the smaller axis. The following shall apply:

- narrow: (0,8 ± 0,2) mm
- medium: (1,2 ± 0,2) mm
- wide: (1,7 ± 0,3) mm

Other widths shall be subject to agreement.

4.4 Behaviour in falling ball test

In the test in accordance with subclause 5.5 a maximum of 1 in 20 specimens may break.

The specimen shall be deemed to have broken if it shatters or splits along the whole length.

If more than one specimen breaks, the test must be carried out on a further 40 specimens. Of the total of 60 specimens it is permitted for a maximum of 7 to break.

4.5 Behaviour in deformation test

In the test in accordance with subclause 5.6 the flattening of the smooth and corrugated pipes must not exceed 10 % of the original outside diameter of the pipe.

4.6 Behaviour of corrugated pipes with socket joint in tensile test

In the test in accordance with subclause 5.7 the socket joints must not become loosened. The arithmetic mean value of the elongations produced in 3 tests must not exceed 10 %.

4.7 Behaviour of smooth pipes in socket insertion test

In the test in accordance with subclause 5.8 the pipe end to be inserted into the socket must fit to at least 3/4 of the depth of the socket.

5 Testing

Testing must be carried out on specimens taken from continuous production. In cases of arbitration or for the purposes of third party supervision, the specimens selected must not be tested earlier than 24 hours after manufacture.

5.1 Condition on delivery

Compliance with the requirements specified in subclause 4.1 shall be tested by visual examination.

5.2 Dimensions

The dimensions specified in subclauses 2.2 and 4.3.2 shall be measured to within 0,1 mm (rounded off).

5.3 Water inlet apertures

The water inlet apertures shall be tested by visual examination and by measurement in accordance with subclause 5.2.

The total area of water inlet apertures shall be calculated from the mean value of 40 individual measurements and the number of apertures per metre and expressed in cm²/m.

5.4 Weight

The weight shall be determined by weighing 3 specimens and compared with the minimum weight dealt with in subclause 2.4.

5.5 Falling ball test

The impact strength dealt with in subclause 4.4 shall be tested using the test apparatus shown in figure 2 on specimens of (200 ± 5) mm in length. Before the test the specimens shall be kept at a temperature of (0 ± 1) °C for a minimum period of 1 hour. Each specimen shall be tested within 10 seconds of removal from the cooling unit.

The falling hammer may only hit the crown of the specimen once. The location of the water inlet apertures in relation to the point of impact of the falling hammer shall not be taken into account.

The falling hammer must be able to slide in the guide without significant friction.

Weight of falling hammer:

For smooth pipes 400 g, for corrugated pipes 800 g.

Height of fall:

For smooth pipes 750 mm, for corrugated pipes 1000 mm.

5.6 Deformation test

5.6.1 Corrugated pipes

A section of pipe measuring (200 ± 5) mm in length shall be tested between two parallel plates. The loading shall be 1 N/cm² based on the projected area of the specimen (length of specimen X outside diameter of pipe). The specimen shall be subjected to the calculated load at a temperature of (23 ± 2) °C for a period of 21 days. Subsequently the flattening of the outside diameter of the pipe shall be measured under load and the percentage deformation in relation to the original diameter shall be calculated.

The test shall be carried out on 2 specimens.

5.6.2 Smooth pipes

5.6.2.1 Pipes up to DN 90

As described in subclause 5.6.1.

5.6.2.2 Pipes above DN 110

The deformation test shall be carried out in accordance with subclause 5.6.1 but with two 120° prisms being used instead of the parallel plates.

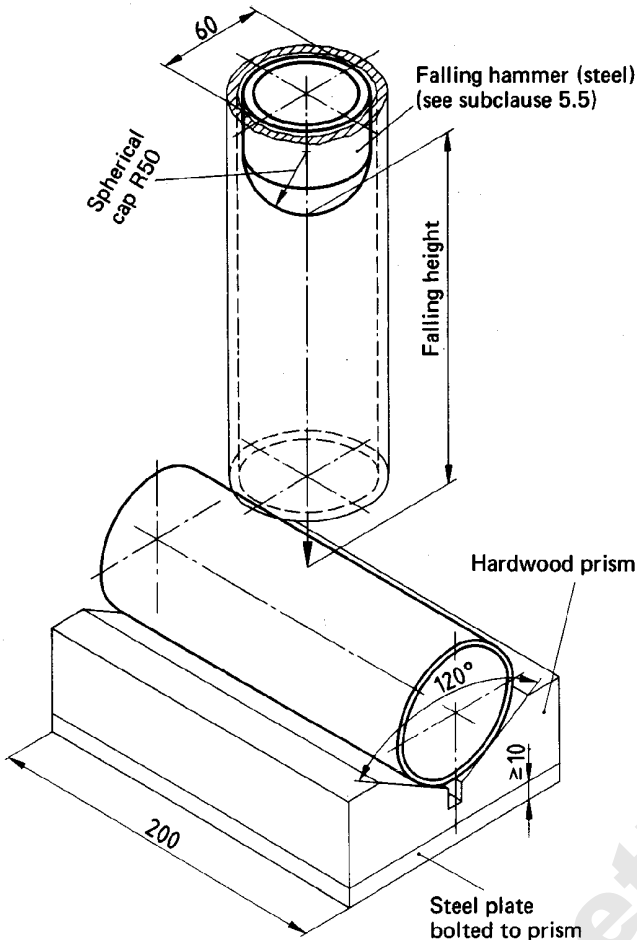

Figure 2. Test apparatus for falling ball test

5.7 Tensile test on corrugated pipes with socket joint

The tensile test shall be carried out on 3 sections of pipe of (700 ± 10) mm in length at a temperature of (23 ± 2) °C, the sections being cut in the middle and reconnected by means of a socket.

The specimen shall first be tensioned by subjecting it to a load of 50 N for 15 seconds.

One minute after the load is released the preliminary load of 10 N shall be applied and measuring marks made on the specimen spaced at intervals of (500 ± 5) mm.

The specimen shall then be subjected to a load of 150 N (for DN 50 and DN 65) or 200 N (for DN 80 or greater) and the distance between the measuring marks measured after 10 minutes.

5.8 Insertion test on smooth pipes with socket joint

A smooth pipe end without slits shall be twisted manually into a section of pipe with a socket and the depth of insertion be measured.

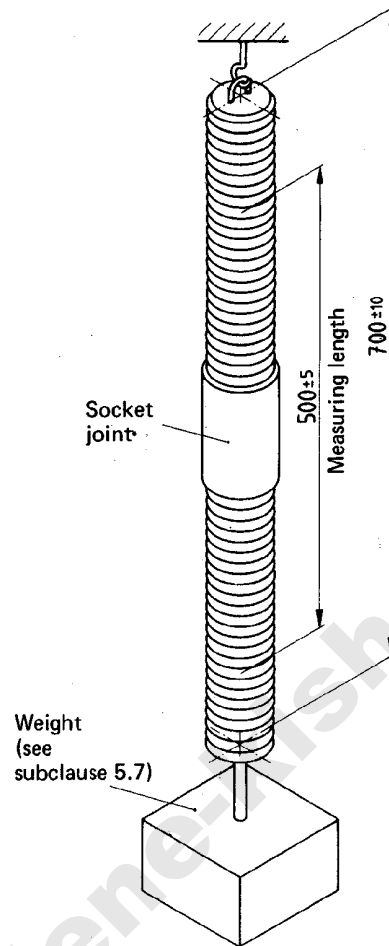

Figure 3. Test apparatus for tensile test on pipe/socket joint

5.9 Marking

The marking dealt within clause 7 must be checked by visual examination for completeness and legibility.

6 Verification of suitability, internal control and supervision

6.1 General

Compliance with the requirements specified in clause 4 must be established by verification of suitability and ensured by internal control and third party supervision.

Before the contract of supervision takes effect the test centre ¹⁾ must ensure that the manufacturer guarantees on the basis of his testing equipment and testing personnel that the continuous production will be controlled in accordance with the specifications of this standard.

6.2 Verification of suitability

6.2.1 Testing of pipes

The suitability of the drain pipes shall be verified by test certificates provided by an authorized test centre ¹⁾. For this purpose one test in accordance with clause 5 must be carried out for each nominal size registered for quality control from 2 different production runs. The specimens

¹⁾ Information available from *Gütegemeinschaft flexible Dränrohre* (Quality control association for flexible drain pipes), Dyroffstraße 2, 5300 Bonn

for the initial test may be submitted by the manufacturer. For the second approval test the specimens shall be selected by the test centre. In this case the requirements specified in subclause 6.3.2 shall be tested.

6.3 Internal control and third party supervision

6.3.1 Internal control

The manufacturer of drain pipes must carry out internal control on the production on his own responsibility. The scope of the tests must ensure the uniform quality of the drain pipes. All test results must be retained for a period of 5 years.

Internal control must include at least the tests specified in table 3.

6.3.2 Third party supervision

Third party supervision must be carried out at least twice annually by an authorized quality control association or an authorized test centre on the basis of a contract of supervision.

Third party supervision shall include:

- checking the testing equipment of the pipe manufacturer
- inspection of records of internal control in accordance with subclause 6.3.1
- selection of specimens for third party supervision of all nominal sizes manufactured. The specimens must be taken by the tester or the representative of the test centre responsible for the third party supervision from the store of the production plant or from the production released for delivery and subjected to the tests specified in table 3.

6.4 Test certificate

The test centre must prepare a test certificate on the results of the tests and any repeat tests.

6.5 Repeat test

If a test carried out in the framework of third party supervision results in failure, a repeat test must be carried out at the latest 4 weeks after conclusion of the first test.

7 Marking

7.1 Corrugated pipes

Each corrugated pipe must bear the following permanent markings at maximum distances of 5 m apart:

- DIN 1187
- manufacturer's mark
- nominal size
- year of manufacture

7.2 Smooth pipes

Each smooth pipe must bear the following permanent markings in at least one place:

- DIN 1187
- manufacturer's mark
- nominal size
- year of manufacture

7.3 Nests and stacks of pipes

Nests and stacks of pipes must be provided with an additional weatherproof tag bearing the following information:

- DIN 1187
- manufacturer's mark
- nominal size
- year of manufacture
- width range of water inlet apertures

In addition, for nests of pipes the length of the pipe and the total weight must be specified.

Table 3. Scope and frequency of internal control and third party supervision

No.	Pipe type	Test	Frequency of test per nominal size (DN)		Requirement as specified in subclause	Testing in accordance with subclause
			Internal control	Third party supervision		
1	Corrugated and smooth	Condition on delivery	6 times in 24 hours	At least twice annually	4.1	5.1
2	Corrugated	Dimensions	Once in 24 hours		2.2	5.2
	Smooth		6 times in 24 hours			
3	Corrugated and smooth	Water inlet apertures	On change in production conditions		4.3	5.3
4	Corrugated	Weight per m	6 times in 24 hours		2.4	5.4
5	Corrugated and smooth	Falling ball test	Once in 24 hours		4.4	5.5
6	Corrugated	Deformation test	On change in production conditions		4.5	5.6.1
	Smooth					5.6.2
7	Corrugated	Tensile test	On change in production conditions		4.6	5.7
8	Smooth	Insertion test	3 times in 24 hours	4.7	5.8	
9	Corrugated and smooth	Marking	3 times in 24 hours	7	5.9	

Standards referred to

- DIN 1185 Part 1 Drainage; control of soil water balance by drainage with pipes; open-ditch drainage and amelioration of the subsoil; general instructions and special cases
- DIN 1185 Part 2 Drainage; control of soil water balance by drainage with pipes, open-ditch drainage and amelioration of the subsoil; important data for planning and dimensioning
- DIN 1185 Part 3 Drainage; control of soil water balance by drainage with pipes, open-ditch drainage and amelioration of the subsoil; construction
- DIN 1185 Part 4 Drainage; control of soil water balance by drainage with pipes, open-ditch drainage and amelioration of the subsoil; design and "as completed" drawings
- DIN 1185 Part 5 Drainage; control of soil water balance by drainage with pipes, open-ditch drainage and amelioration of the subsoil; maintenance
- DIN 7748 Part 1 Plastic moulding materials; unplasticized polyvinyl chloride (PVC-U) moulding materials; classification and designation

Further Standards

- DIN 1180 Clay drainpipes; dimensions, requirements, testing

Previous editions

- DIN 1187: 01.71, 07.75

Amendments

Compared with the July 1975 edition the following amendments have been made:

The dimensions and tolerances have been adapted to the new basic standards on plastics pipes. The tests have been revised and for corrugated pipes the tensile impact test replaced by a falling ball test.

Explanations

Due to the great significance of mechanical pipe laying in accordance with DIN 1187 the responsible Technical Committee III 3 of *Normenausschuss Wasserwesen (NAW)* (Water Practice Standards Committee) has decided to carry out investigations in cooperation with *Gütegemeinschaft flexible Dränrohre* with regard to the stresses occurring in this method of laying.

It is intended to verify by these investigations that the requirements and test methods specified in this standard are sufficient to take this application into account.

International Patent Classification

E 02 B 11/00